

# Tate Andale Model IS Single Basket Strainer

**Where reliability and durability are a necessity and not an option—  
The "IS" strainer is the answer.**

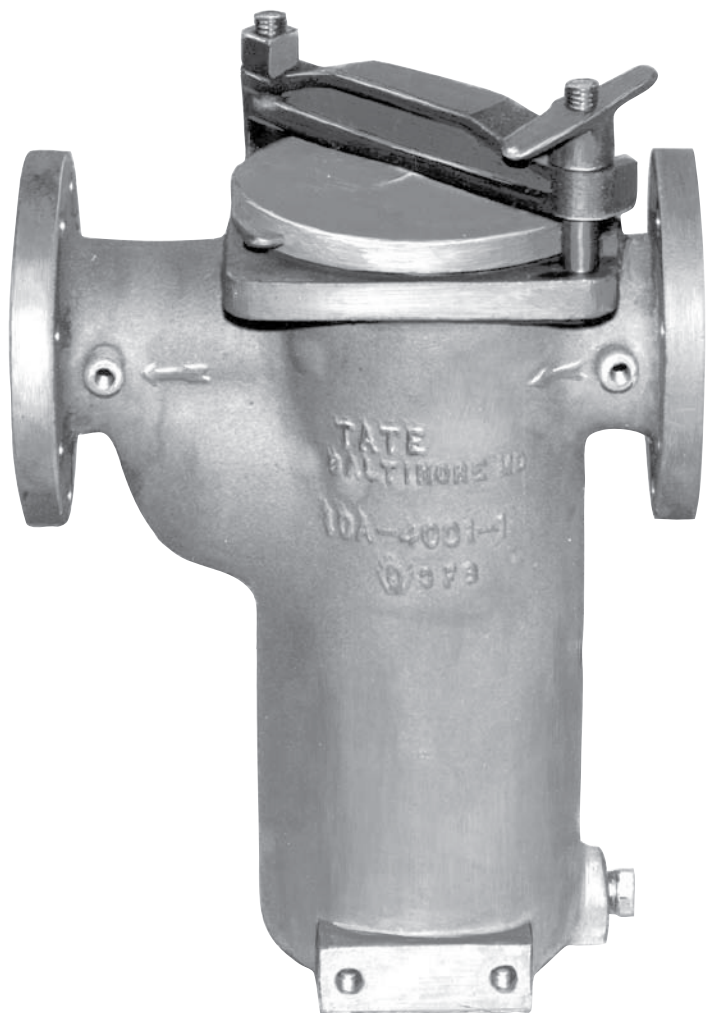

## Description

The rugged, heavy duty Model **IS** is the strainer to select when operating conditions demand carbon steel, stainless steel or bronze construction. It features the thickest body walls on the market, guaranteeing high corrosion allowance and unsurpassed longevity. High open area ratios reduce operating costs by lowering maintenance requirements, while the quick-opening cover also cuts maintenance time and costs. The outstanding longevity of the Model **IS** plus its low operating expenses combine to give you a strainer with the lowest life cycle cost available.

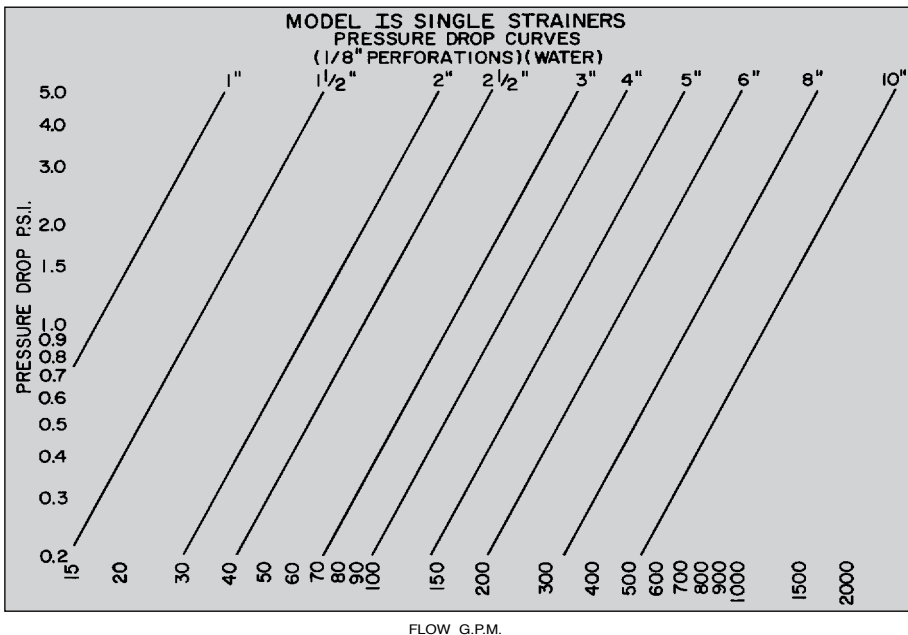
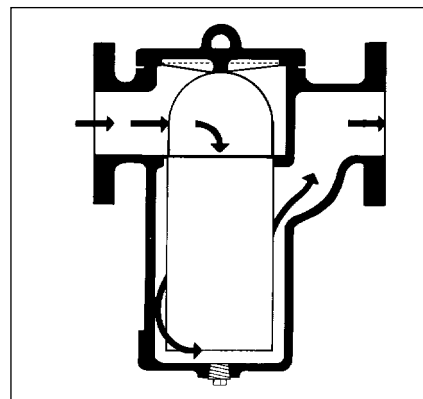

FLOW G.P.M.

### Standard Features

- The large basket (straining ratios from 5.6 to 1 to 15.5 to 1) means longer periods of time between cleaning and lower maintenance costs to the customer.
- Heavy duty body casting is field proven to provide years of trouble free service.
- Quick opening, yoked cover which means less time required for maintenance and thus lower maintenance costs.
- Strainer body available in steel, bronze, stainless steel, Alloy 20, Hastelloy B and many others.
- Vent in cover and large drain connection on straining chamber enables you to clean strainer body in-line.
- 300 pound design available where required.

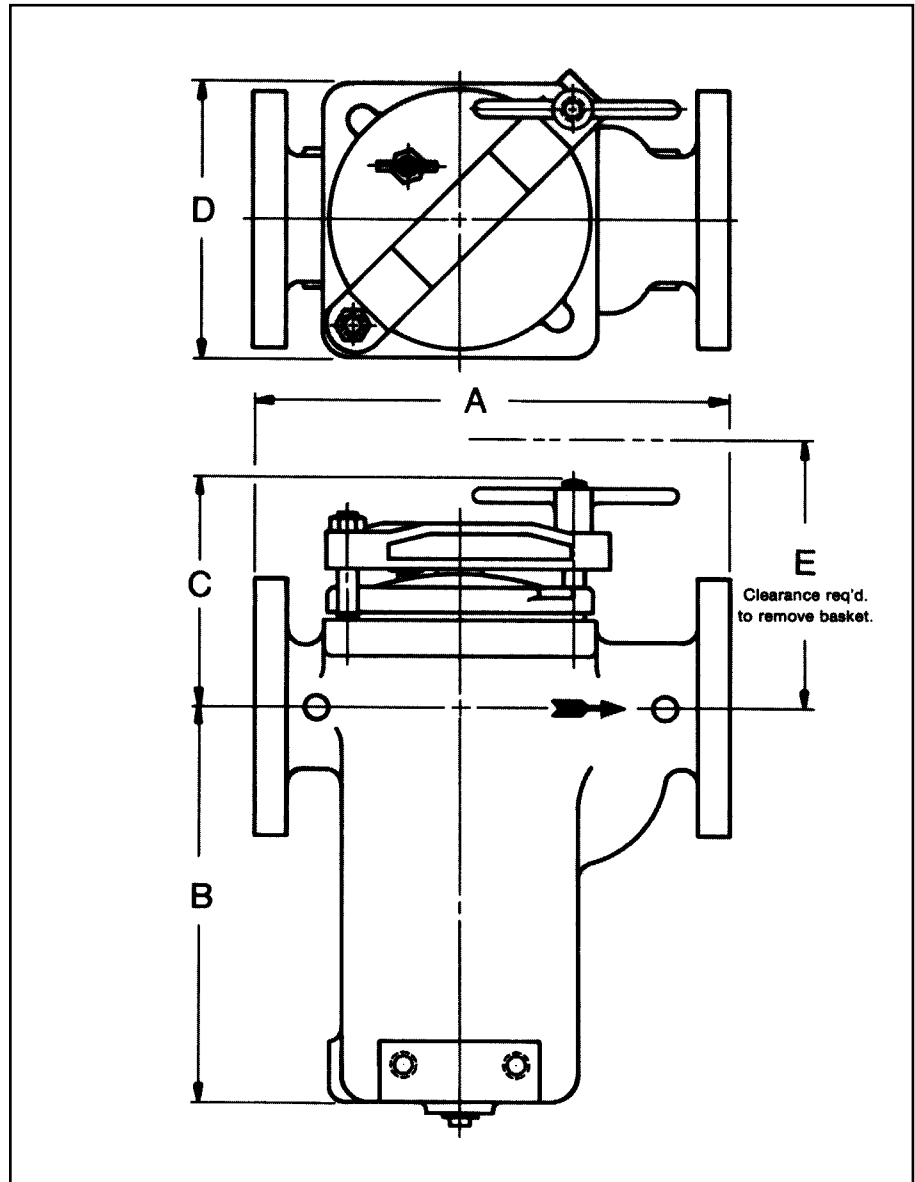

### Model IS Dimensions (Approx.) 150 PSIG

SIZE (Inlet Dia.)	1"	1¼"	1½"	2"	2½"	3"	4"	5"	6"	8"
<b>A</b> face-to-face	6⅜	8⅝	8¾	10⅝	13⅝	13⅞	16	19⅝	21¾	24⅞
<b>B</b> bottom to center line	4⅝	5⅝	5⅞	8⅞	11⅞	11⅞	16	18⅞	21⅝	24⅞
<b>C</b>	3⅞	3⅞	3⅞	4¾	6¼	6¼	7⅞	9⅞	10½	13¼
<b>D</b>	3¼	5	5	5¼	8	8	9¼	15	16	17
<b>E</b>	6	7½	7½	11½	16¼	16¼	20¾	24½	29	36
Weight (lbs.)	11	21	23	34	80	85	132	220	295	470