

Tate Andale Model R and S Twin Basket Strainers

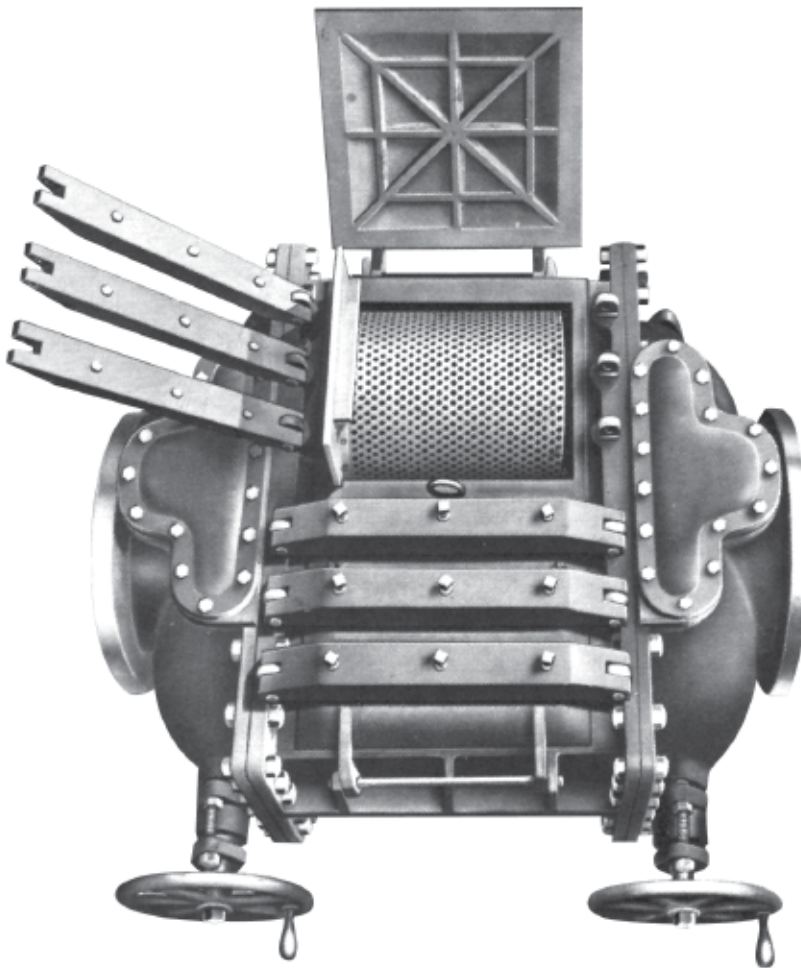

Description

Tate Andale Model R and S twin strainers differ from the other twin strainers in the Tate Andale product line in their basic design. The **Model R and S** units feature bodies with a low profile. Straining baskets are mounted parallel to the pipeline with relatively straight line fluid flow through the strainer.

The **Model R** strainers are available in sizes 4" thru 36". Maximum operating pressure for units thru 16" size is 100 PSIG. The 20" and 24" units are designed for 50 PSIG. The 30" and 36" units are designed for 125 PSIG working pressure and are furnished with electric motor valve operators featuring torque control to insure positive valve seating.

The **Model S** strainer incorporates all design features of the **Model R** plus increased basket area. The **Model S** features multiple baskets in each chamber which yield basket areas that double the baskets areas of the **Model R**.

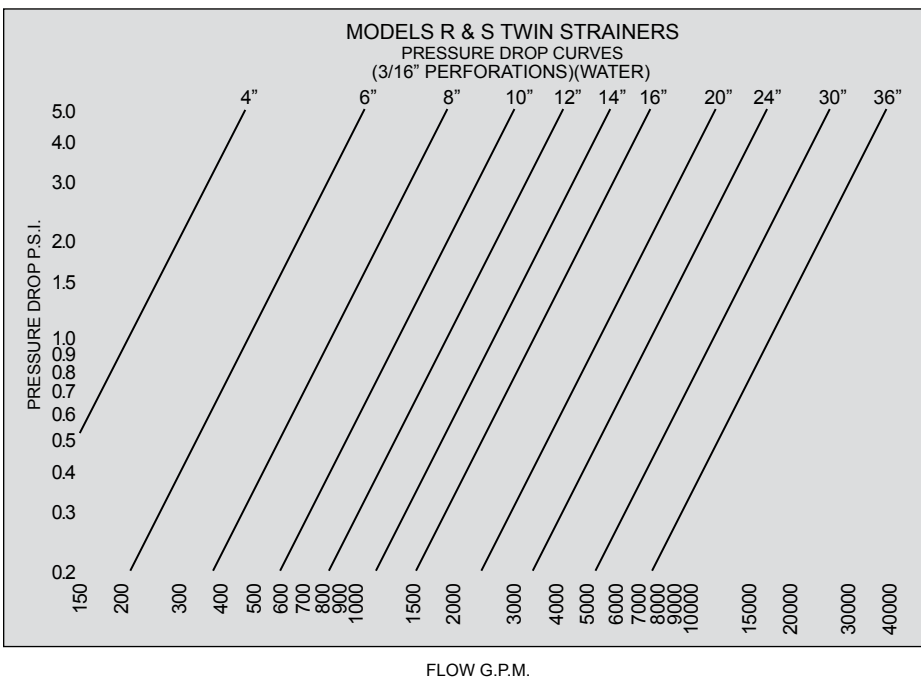
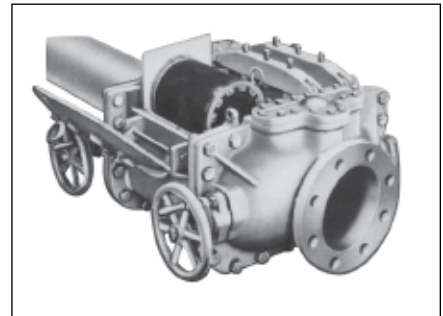

Typical Strainer Specification

The strainer shall be a gate valve twin basket type, capable of handling _____ (fluid) at a flow rate of _____ GPM with an approximate pressure drop (clean) of _____ PSIG. The strainer shall be Model R (S) as manufactured by Tate Andale, Inc. and suitable to a working pressure of _____ PSI and a working temperature of _____ °F.

The strainer body shall be cast iron construction with _____" flanged inlet and outlet connections and shall have a multiple yoked access cover.

The body shall be a low profile design with floating valve discs, wedge-action seating with instant release before valve moves to eliminate scoring.

Tate Andale Model R and S Twin Basket Strainers

The cover shall be a hinged type with multiple yokes.

The two strainer baskets shall be of 304 Stainless Steel construction with ___ inch diameter perforated openings.

Standard Materials

Body, valve housings, valve discs and access covers.....Cast Iron
 Valve Screws (thru 24").....Brass
 Valve Screws (30" & 36").....304 Stainless Steel
 Valve Ring.....Rubber
 Basket.....304 Stainless Steel

Standard Features

- Gate type valves with floating valve discs
- Wedge-action seating of valves, with instant release before valve moves, eliminates scoring while perpendicular seating provides positive seal
- Positive external valve position indicators
- Non-rising stem (thru 24")
- Easily replaceable valve stem packing
- Right or left hand assembly
- Air vents included on access covers
- Equalizing and drain connections on each chamber (pipes, fittings and valves by purchaser)

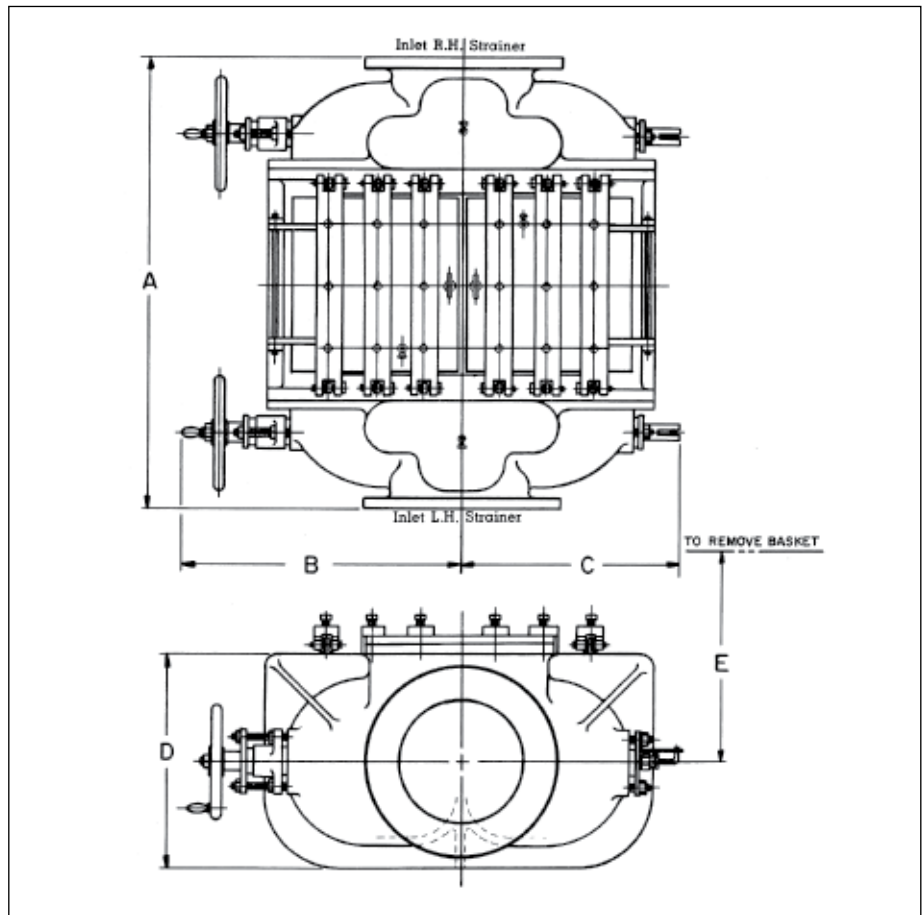

- All wearing parts replaceable without removing strainer from line, except 4" size
- Electric motor driven valve operators (30" & 36") available by special order only

Optional Features

- Chain drive (handwheels interlocked)
- Equalizing pipe, fittings and valves
- Zinc anodes for salt water
- Increased straining ratio (type S)
- Monel or 316 Stainless Steel baskets

Model R and S Dimensions (Approx.) 125 PSIG

SIZE	4"	6"	8"	10"	12"	14"	16"	20"	24"	30"	36"
A	24 ¹ / ₈	29 ⁵ / ₈	34 ¹ / ₈	37 ⁷ / ₈	43 ¹ / ₂	47 ¹ / ₈	54 ¹ / ₈	70	85 ⁵ / ₈	105	120
B	13 ³ / ₁₆	18 ¹ / ₄	20 ¹ / ₂	23 ⁵ / ₈	26 ¹³ / ₁₆	30 ⁵ / ₁₆	33 ⁵ / ₁₆	39 ⁵ / ₁₆	44 ⁷ / ₈	111 ¹ / ₄	142 ¹ / ₂
C	11 ¹ / ₄	13 ¹³ / ₃₂	15 ²⁵ / ₃₂	18 ¹ / ₁₆	21 ¹ / ₁₆	24 ⁷ / ₁₆	27 ⁷ / ₁₆	33 ⁷ / ₁₆	39 ¹ / ₂	44 ⁷ / ₈	60 ¹ / ₁₆
D	10 ¹ / ₂	13 ⁵ / ₈	16 ¹ / ₈	18 ⁵ / ₈	20 ³ / ₄	25	28 ¹ / ₄	32 ¹ / ₂	37 ³ / ₄	48 ¹ / ₂	65
E	18	21 ⁵ / ₁₆	25 ³ / ₈	26 ¹³ / ₁₆	31 ³ / ₄	34 ¹³ / ₁₆	33 ⁵ / ₈	42 ⁷ / ₁₆	50	64	84
WEIGHT (lbs.)	350	650	1000	1500	2100	3100	4000	5900	8850	24000	38000