

Tate Andale Model ID Twin Basket Strainers

*Where reliability and durability are a necessity and not an option—
The "ID" is the answer.*



Description

Model ID duplex strainers are engineered for reliability and durability. The tapered plug valve, which diverts flow from one basket chamber to the other, has been designed to "lift" during the change-over process. This virtually eliminates all wear on the plug and body. Reversing the lifting operation reseats the plug, minimizing fluid bypass. The heavy duty castings are the thickest available, providing the highest corrosion allowance and longest life of any plug-type strainer. Designed with straining ratios of up to 15:1, the Model ID is one of the most economical strainers to operate. When you factor in purchase and operating expenses, plus longevity, the Model ID delivers the lowest life-cycle cost of any plug-type strainer in the industry.

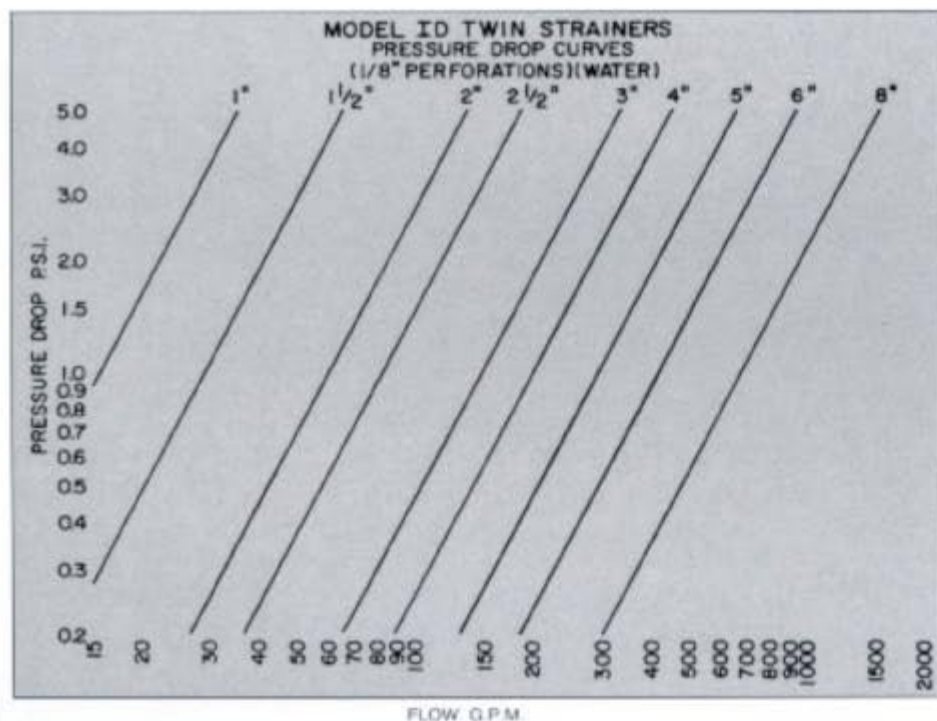
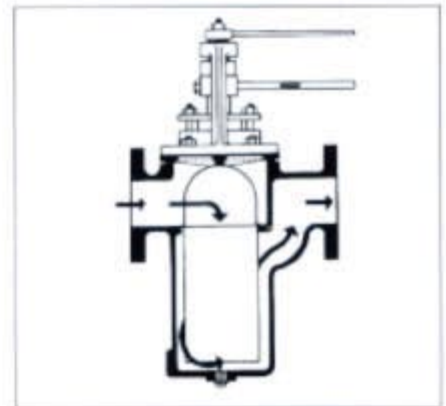

Standard Features

- The Model ID strainers are available in sizes 3/4" through 8" for system pressures up to 150/300 PSIG. The access cover is yoked or bolted.
- The large baskets (straining ratios from 6.2 to 1 to 15.5 to 1) means longer periods of time between cleaning and lower maintenance costs to the customer.
- Heavy duty cast body is field proven to provide longest trouble free life of any plug type duplex industrial strainer.
- Precision machined plug valve minimizes bypassing of liquid, while lifting lever raises plug prior to switching so as to eliminate the scoring of the seats.
- Quick opening yoked covers means less time required for maintenance and thus lower maintenance costs, thus lower operating costs.
- Available in cast steel, bronze, stainless steel, Alloy 20, Hastelloy B and many other materials.
- Vent valve in covers and large drain connections on each chamber.
- 300 pound design available.

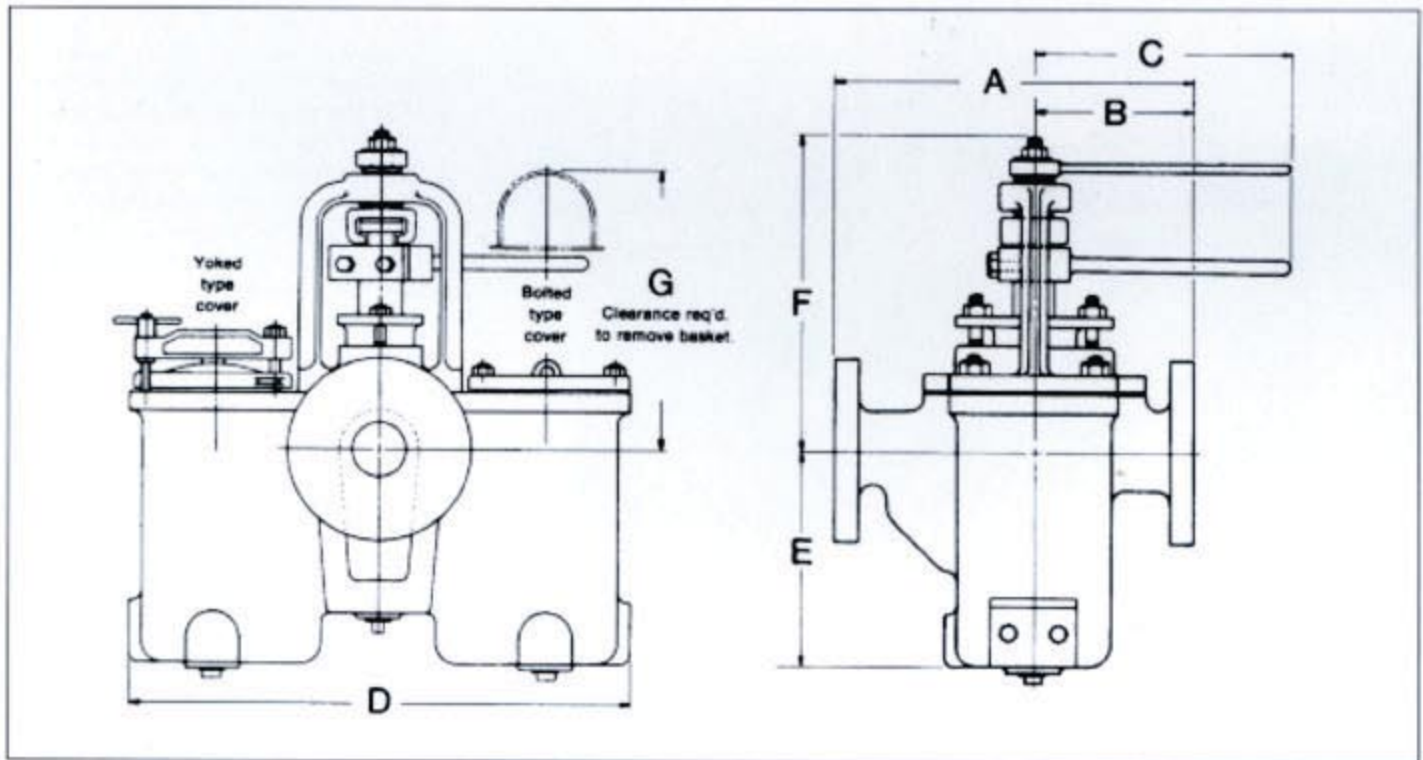

Model ID Dimensions (Approx.) 150 PSIG

SIZE (Inlet Dia.)	3/4"	1"	1 1/4"	1 1/2"	2"	2 1/2"	3"	3 1/2"	4"	5"	6"	8"
A Face to face	6 1/4	6 1/4	8 1/4	8 1/4	10 1/4	14 1/4	14 1/4	15 1/2	16 1/4	19 1/4	21 1/4	26 1/4
B Bottom to center line	3	3 1/4	4 1/4	4 1/4	5 1/4	6 1/4	6 1/4	7	7 1/4	8 1/4	9 1/4	10 1/4
C	4 1/2	4 1/2	7 1/4	7 1/4	9 1/4	11 1/4	11 1/4	11 1/4	11 1/4	14	14	14
D	10	10	14 1/4	14 1/4	17 1/4	23 1/4	23 1/4	25 1/4	28	35 1/4	40	42 1/4
E	4 1/4	4 1/4	5 1/4	5 1/4	7 1/4	11 1/4	11 1/4	12 1/4	14 1/4	17 1/4	21 1/4	27 1/4
F	5 1/4	5 1/4	10 1/4	10 1/4	12 1/4	15 1/4	15 1/4	16	16 1/4	13 1/4	14 1/4	15 1/4
G	6	6	8 1/4	8 1/4	12 1/4	16 1/4	16 1/4	18 1/4	20 1/4	24 1/4	29	37 1/4
Weight (lbs.)	29	30	67	71	125	275	280	390	415	745	1040	1260