

# Tate Andale Model AL and AH Twin Basket Strainers.

**Where reliability and durability are a necessity and not an option—  
The “AL” is the workhorse of the industry.**

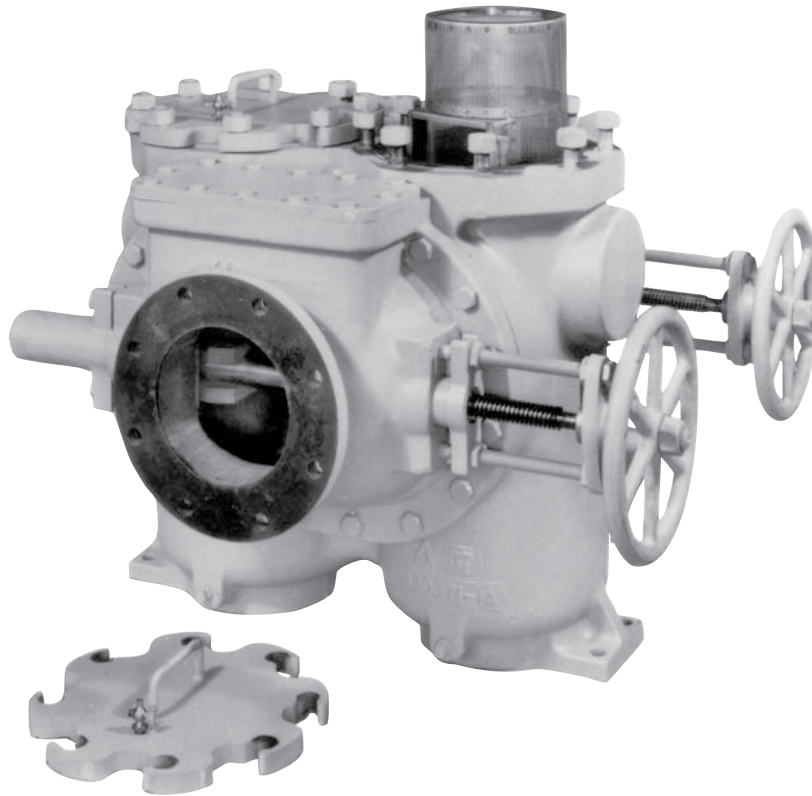

## Description

The Model **AL** is a cast, gate valve duplex strainer offering bank vault construction and quality. Designed for longevity, the Model **AL** has only one set of moving parts—the gate valves. These sliding valves have wedge seating, meaning they are wedged to the body when in the closed position. Therefore the valves do not come in contact with the body during the chamber change-over process, virtually eliminating wear. The body walls are the thickest in the industry, providing decades of service. Easy operating features include quick opening covers, cover-lifting davits, and interlocking chain drive on the valve hand wheels, allowing both valves to operate with the turn of one hand wheel. And with the lowest pressure drop available, it becomes the least expensive strainer to operate. The outstanding longevity of the Model **AL** plus its low operating expenses combine to give you a strainer with the lowest life cycle cost available.

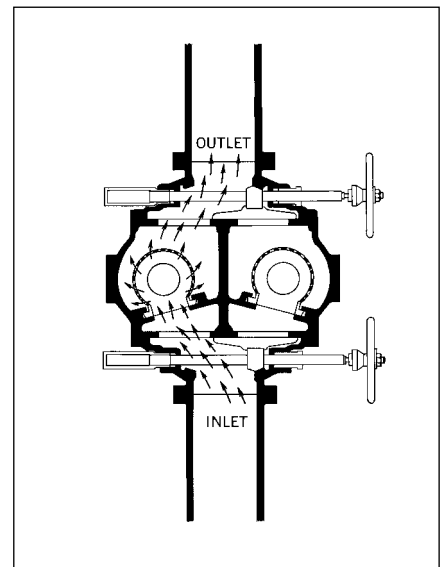
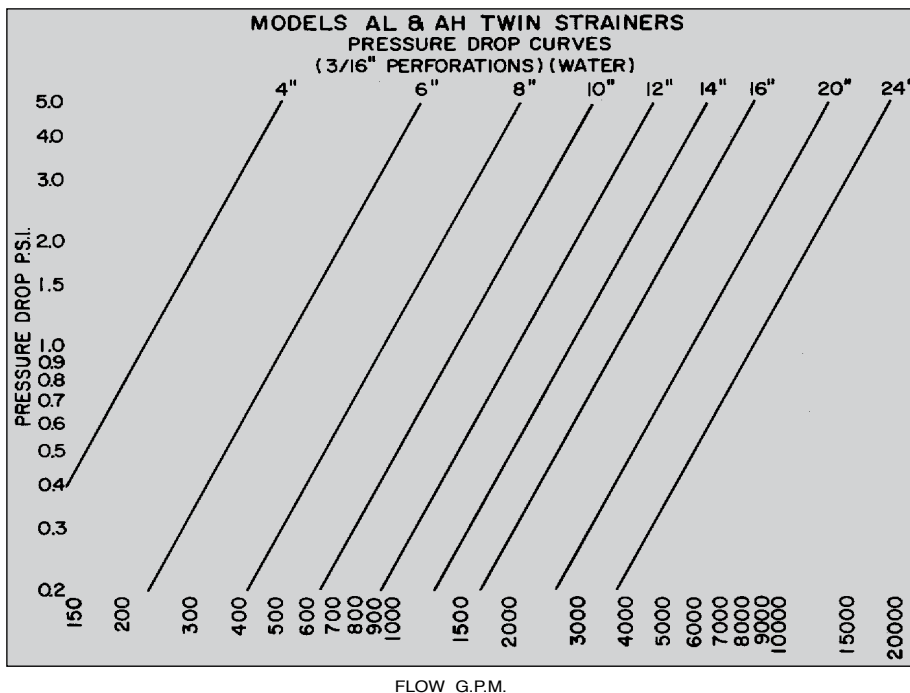

### Standard Features

- The side entry baskets provide the “AL” strainers with the lowest pressure drop of any industrial strainer. This means that your system is less expensive to operate.
- The “AL” strainer has sliding gate valves with wedge seating. This means that the sealing surface of the valve disc and strainer body do not come in contact while the disc is being switched from one basket to the other. This extends the usable life of the strainer and reduces its overall cost.
- The strainer utilizes a natural rubber ring as the sealing surface between the valve disc and the strainer body. This provides a seal which is ten times more effective than the metal to metal alternative.
- The strainer includes steel plate access covers suitable for rough handling and maximum durability.
- Quick opening access covers have elongated bolt holes, requiring only the loosening of the retaining nuts for cover removal.
- Each basket utilizes a removable cover in addition to inlet port for ease of cleaning.
- The valve position indicators are in plain view to enable the operator to quickly determine valve position. This means that the likelihood of operator error in switching the valves, with potentially disastrous results, is significantly reduced with the “AL”.
- Non-rising stem valve screws are housed in bronze sleeves and are never in contact with the liquid.
- Vent valves on doors and large equalizing and drain connections on each chamber.

### Optional Features

- Chain drive (handwheels interlocked)
- Equalizing lines and valves
- Valverings of bronze or steel
- Higher design pressures
- Semi-automatic operation
- Lifting davit
- Manual backflushing allows operator to clean baskets without removing them from the strainer.
- Also available in 250 pound flanged configuration (Model AH).

- Other materials of construction available upon request.

### Standard Materials

- Body, valve housings, valve discs, glands, handwheels . . . . . Cast Iron
- Guides . . . . . Steel
- Access covers . . . Steel plate
- Enclosed valve screw . . . . . Steel
- Valve rings . . . . . Natural rubber stock
- Baskets . . . . . 304 Stainless Steel

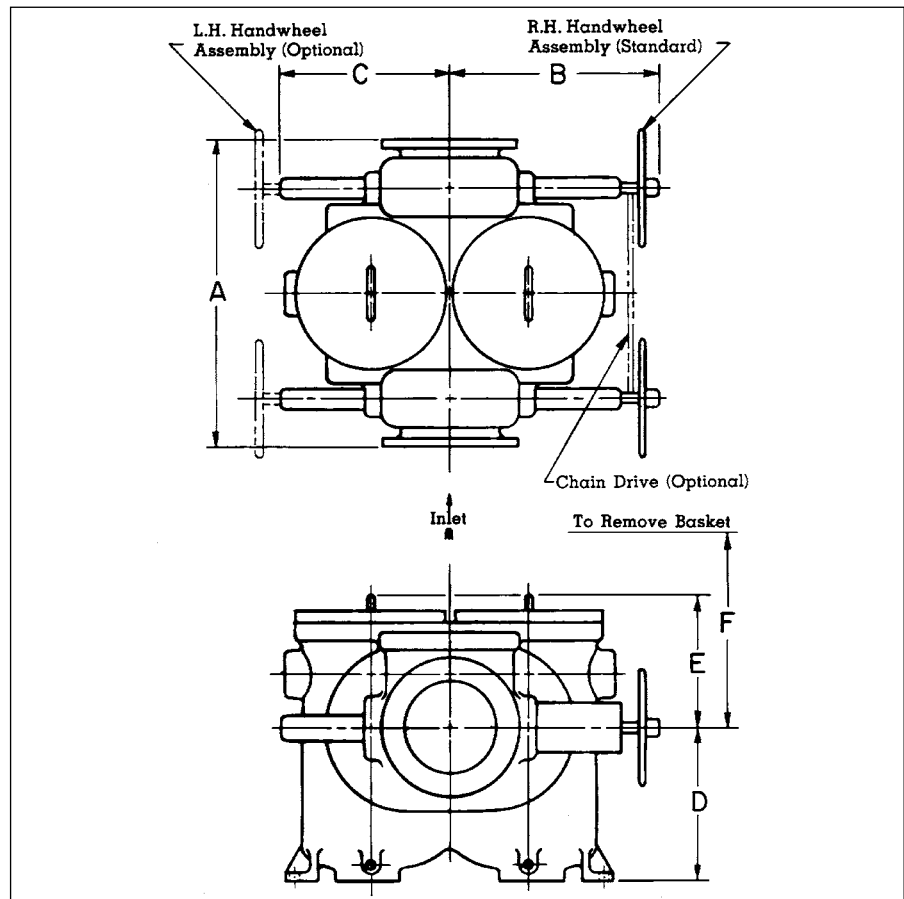

### Model AL Dimensions (Approx.) 125 PSIG

SIZE (Inlet Dia.)	4"	6"	8"	10"	12"	14"	16"	20"	24"
<b>A</b>	24 $\frac{3}{4}$	29 $\frac{3}{8}$	34 $\frac{3}{8}$	37 $\frac{3}{8}$	43 $\frac{1}{2}$	47 $\frac{3}{8}$	51	66	75 $\frac{1}{2}$
<b>B</b>	15	18 $\frac{3}{4}$	23 $\frac{1}{2}$	25 $\frac{3}{8}$	29 $\frac{3}{4}$	32 $\frac{3}{8}$	35	43 $\frac{1}{2}$	48 $\frac{3}{4}$
<b>C</b>	10 $\frac{3}{8}$	15	16 $\frac{3}{4}$	19 $\frac{1}{4}$	22 $\frac{3}{8}$	25 $\frac{1}{4}$	27 $\frac{3}{8}$	35	40 $\frac{1}{4}$
<b>D</b>	9 $\frac{1}{4}$	12 $\frac{3}{8}$	16 $\frac{3}{4}$	18 $\frac{3}{8}$	21 $\frac{3}{4}$	24 $\frac{1}{2}$	26 $\frac{3}{8}$	34	38 $\frac{3}{4}$
<b>E</b>	9	12	14	15 $\frac{1}{2}$	18	20 $\frac{3}{4}$	24	29	34
<b>F</b>	21	29	35	40	47	54	61	76	88 $\frac{3}{8}$
<b>Weight (lbs)</b>	465	930	1600	2250	3700	4200	5300	9425	13500

### Model AH Dimensions (Approx.) 250 PSIG

SIZE	4"	6"	8"	10"	12"	14"	16"	20"	24"
<b>A</b>	24 $\frac{3}{4}$	30 $\frac{1}{2}$	35 $\frac{3}{8}$	39 $\frac{1}{4}$	45	52	54 $\frac{1}{2}$	73 $\frac{1}{2}$	79 $\frac{1}{2}$
<b>B</b>	15	18 $\frac{3}{4}$	23 $\frac{1}{2}$	25 $\frac{3}{8}$	29 $\frac{3}{4}$	32 $\frac{3}{8}$	35	45	50 $\frac{1}{2}$
<b>C</b>	10 $\frac{3}{8}$	13 $\frac{3}{8}$	16 $\frac{3}{4}$	19 $\frac{1}{4}$	22 $\frac{3}{8}$	25 $\frac{1}{4}$	27 $\frac{3}{8}$	35	40 $\frac{1}{4}$
<b>D</b>	9 $\frac{1}{4}$	12 $\frac{3}{8}$	16 $\frac{3}{4}$	18 $\frac{3}{8}$	21 $\frac{3}{4}$	24 $\frac{1}{2}$	26 $\frac{3}{8}$	34 $\frac{1}{2}$	39 $\frac{1}{4}$
<b>E</b>	9	12 $\frac{1}{4}$	14 $\frac{1}{4}$	15 $\frac{3}{8}$	18 $\frac{3}{8}$	22 $\frac{1}{2}$	24	29 $\frac{1}{2}$	35 $\frac{1}{4}$
<b>F</b>	21	29	35	40	47	54	61	76	88 $\frac{3}{8}$
<b>Weight (lbs)</b>	485	975	1660	2350	3850	5400	7000	11000	16000